

Manitowoc Cranes

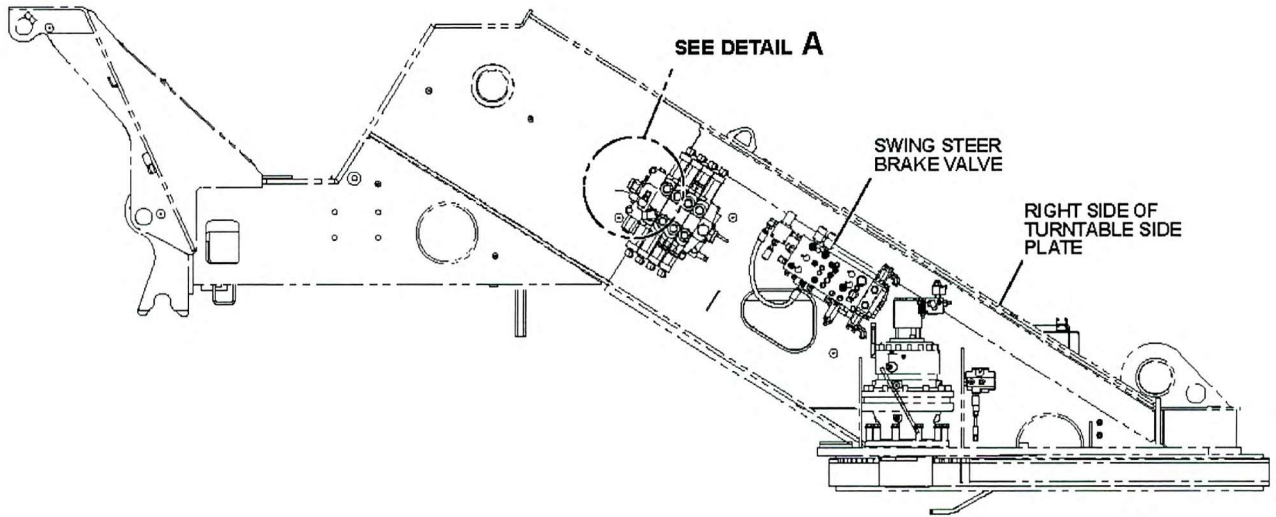

VALVE INSTALLATION VIEW

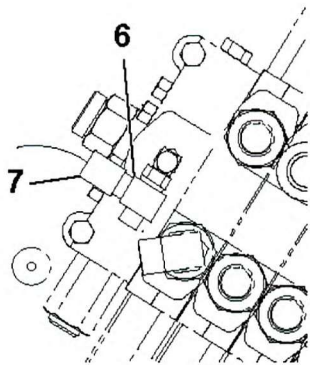

DETAIL A
LOAD SENSE PRESSURE SWITCH

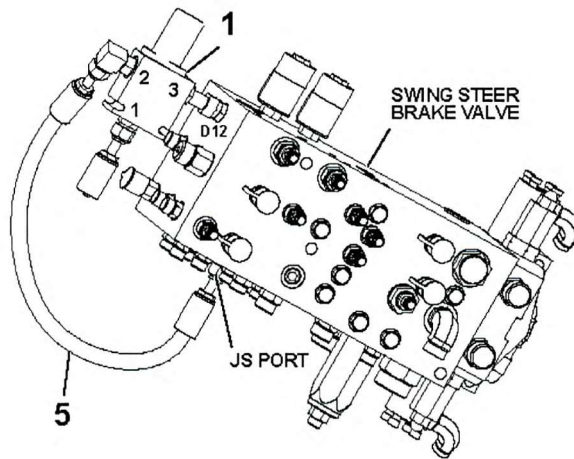

ISO VIEW

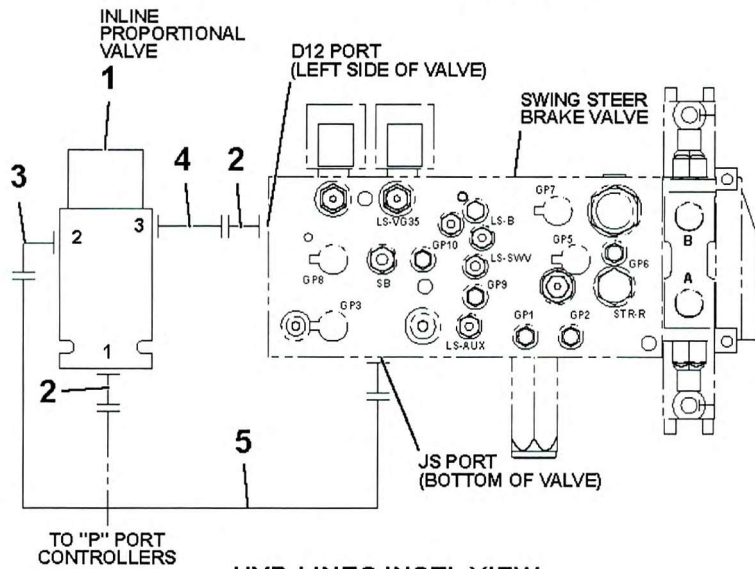

HYD LINES INSTL VIEW